

NEW HAPTIC ARM EXOSKELETONS FOR ROBOTICS AND AUTOMATION IN SPACE (EXORAS)

Goal of the project

The project seeks to develop in Romania the capacity to design and manufacture special assemblies meant to work in the field of Robotic Exploration. The overall goal is to stimulate Romania's participation to international space missions and programs, in collaboration with ESA (European Space Agency), as its 19th member. The practical task is to develop a new haptic arm exoskeleton designed to enable in-space force-feedback telemanipulation with redundant robotic arms.

Short description of the project

EXORAS will provide a new haptic arm exoskeleton for robotic exploration. The exoskeleton is desired to explore future ways of commanding a manipulator arm in space. It will be created a prototype with special features of design, namely several shortcomings of previous telemanipulation systems will be removed. The new system pursues requirements regarding weight, ease of wearing and comfort of the human operator. The project assumes the full design, assembling and testing of the prototype. All aspects are taken into account: kinematics, dynamics, sensorics, wireless control, haptic feed-back, actuation, materials and so on.

Project implemented by

- Technical University of Cluj-Napoca – Coordinator
- University "Transilvania" Brasov – Partner 1
- Politehnica University of Timisoara – Partner 2 (146)

Implementation period

2012 – 2015

Main activities

- Research on the development of exoskeleton haptic systems for robotic exploration (existing solutions and development of new solutions; establishment of basic components with functional and technical specifications)
- Concept, design and assembly (mechanical design, kinematic analysis, development of control software, simulation)
- Testing and optimizing of prototypes (assembling, testing and optimizing of prototypes).

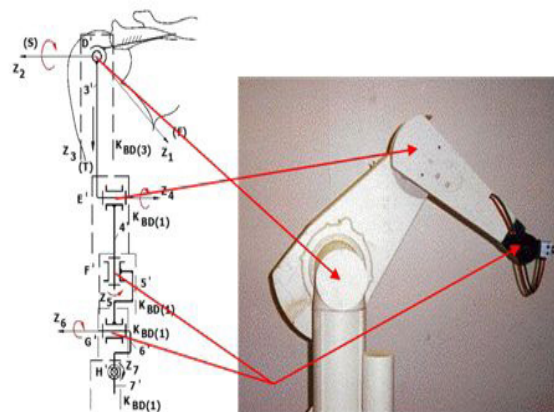

Fig. 1 Corresponding joints of exoskeleton and robot

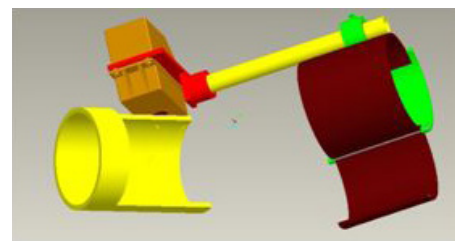

Fig. 2 CAD model of the exoskeleton with servo rotary drive

Results

At this stage, the research work lead to the design and partial implementation of new six solutions of exoskeleton arm. A generic scheme of the general concept from kinematic point of view is given in figure 1.

The design and practical solutions developed until now focused on the elbow and wrist joints. The six variants of exoskeleton under study use:

- servo rotary drive mounted directly on the shaft of the joint (fig. 2)
- linear actuation and transformation of motion (fig. 3)
- free motion and electromagnetic brake (movement transmission via a wire mechanism)
- free motion and electromagnetic brake
- haptic feedback generated by myostimulation
- haptic feedback generated by vibration modules.

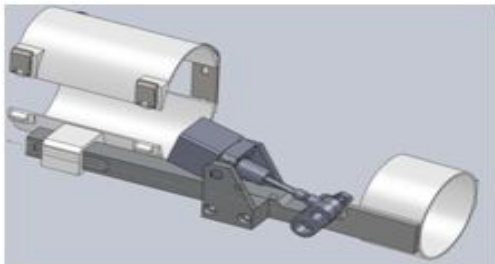

Fig. 3 CAD model of the exoskeleton with linear actuation

From the solutions above, the most convenient alternative proved to be the one using electromagnetic brakes. The CAD model of the assembly (5 degrees of freedom) is shown in figure 4.

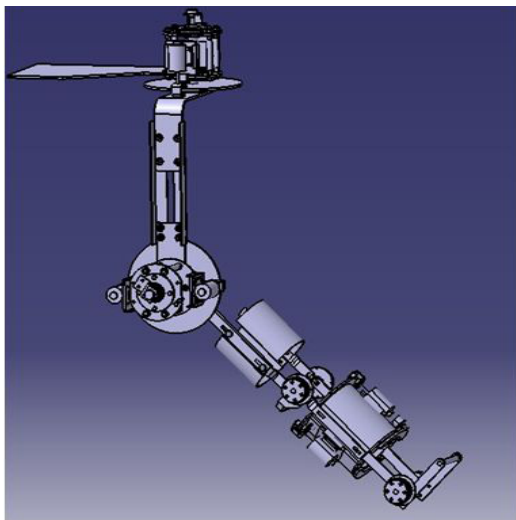

Fig. 4 CAD model of the exoskeleton (5 degrees of freedom) with free motion and electromagnetic brake

Research centre

Mechatronics&Robotics Research Center

Applicability and transferability of the results

- EXORAS fulfills entirely the goal of STAR program (of Romanian Space Agency) that aims the increasing of the research competitiveness for participation of academic entities to activities of ESA, included in the law no. 262/2011 regarding the membership status to ESA.
- This project is going to produce clear benefits to the consortium partners and beyond, regarding the competitiveness of the market for hi-tech mechatronics and robotics. In addition, the gain in knowledge is going to be transferred into higher-education support.

Financed through/by

Funded by the Romanian Space Agency (ROSA) through Contract nr. 13/19.11.2012 within the program STAR 2012 – Projects of RDI, Research direction: S1 Research

Research team

Erwin Lovasz
Valentin Ciupe
Dan Mărgineanu
Corina Gruescu
Iosif Cărăbaș
Eugen Zăbavă
Aurel Diaconu
Inocențiu Maniu
Valer Dolga
Marius Mateaș
Sanda Grigorescu
Cristian Pop

Contact information

Assoc. Prof. Erwin-Christian LOVASZ, PhD
Department of Mechatronics
Address: Bv. Mihai Viteazu 1, RO300222, Timisoara
Phone: (+40) 256 403 569
E-mail: erwin.lovasz@upt.ro